

NSB RED Battery®

Pure Lead - Long Life



The NSB RED Battery® delivers long life for reliable and unreliable grid conditions.





The NSB RED Battery[®] is ideal for use in a range of applications, including telecom backup, cable TV, emergency lighting, railway, oil and gas and more.

- Pure lead electrochemistry greatly increases temp and corrosion resistance, while reducing component aging
- Thin plates deliver large surface area, high power density and low resistance
- Design life 15+ years at 20°C (68°F)
- EUROBAT design life definition: Long Life (12+ years)
- Fast recharging
- Operating temperature range -40°C to +65°C (-40°F to 149°F)
- State-of-the-art automated manufacturing ensures consistency and reliability
- Shelf life of up to 24 months
- Advanced 3 stage terminal design to ensure leak-free operation - brass terminals provide maximum performance
- High modulus Polyphenylene Oxide (PPO) plastic materials designed to withstand extended elevated operating temperatures and maintain high battery compression essential for reliable operation
 - Non-halogenated, thermally sealed plastic casing
 - Flame retardant (UL 94 VO) and LOI of at least 28%
- Approved as non-hazardous cargo for ground, sea, and air transport - DOT 49CFR173.159(d), (i) and (ii)

NorthStar advanced manufacturing

NorthStar products are designed to be ultra-high performance and premium quality, with a much longer lifetime than standard products. But to build batteries to such a high standard requires the latest robotic processing and manufacturing technology. That's why we built the industry's most technologically advanced battery manufacturing facilities in Missouri, USA.

All NorthStar RED Batteries are proudly made in the USA. Our facilities are also built and run to meet the toughest possible environmental requirements, to prevent lead poisoning of the surrounding air, ground and water.





| | NSB 100FT RED | NSB 155FT RED | NSB 170FT RED | NSB 190FT RED |
|-----------------------------|--------------------|--------------------|--------------------|--------------------|
| Height | 287 mm (11.3 in) | 280 mm (11.0 in) | 320 mm (12.6 in) | 320 mm (12.6 in) |
| Width | 108 mm (4.2 in) | 125 mm (4.9 in) | 125 mm (4.9 in) | 125 mm (4.9 in) |
| Length | 396 mm (15.6 in) | 560 mm (22.0 in) | 560 mm (22.0 in) | 560 mm (22.0 in) |
| Weight | 30 kg (67 lbs) | 46 kg (101 lbs) | 52.5 kg (116 lbs) | 56 kg (123 lbs) |
| Terminal Torque | 8.0 Nm (71 in-lbs) | 8.0 Nm (71 in-lbs) | 8.0 Nm (71 in-lbs) | 8.0 Nm (71 in-lbs) |
| 1 hr capacity to 1.70 VPC* | 68 / 71 Ah | 113 / 117 Ah | 124 / 128 Ah | 129 / 132 Ah |
| 3 hr capacity to 1.75 VPC* | 85 / 87 Ah | 130 / 134 Ah | 143 / 147 Ah | 160 / 164 Ah |
| 8 hr capacity to 1.75 VPC* | 97 / 99 Ah | 149 / 153 Ah | 164 / 168 Ah | 183 / 186 Ah |
| 10 hr capacity to 1.80 VPC* | 99 / 100 Ah | 151 / 155 Ah | 166 / 170 Ah | 187 / 190 Ah |
| Float voltage* | 2.28 / 2.27 VPC | 2.28 / 2.27 VPC | 2.28 / 2.27 VPC | 2.28 / 2.27 VPC |
| Impedance (1KHz) | 4.5 mΩ | 3.5 mΩ | 3.3 mΩ | 3.0 mΩ |
| Conductance | 1,150 S | 1,550 S | 1,600 S | 1,750 S |
| Short circuit current | 2,900 A | 3,900 A | 4,100 A | 4,600 A |
| Nominal voltage | 12 V | 12 V | 12 V | 12 V |

* Capacities and float voltages given at 20°C (68°F) and 25°C (77°F)

Technical drawings

NSB 100FT RED

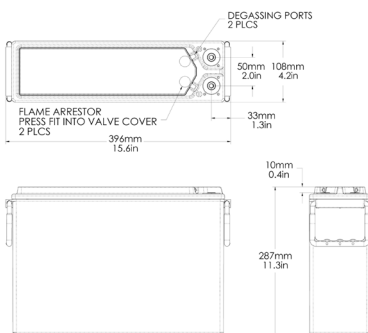

NSB 155FT RED

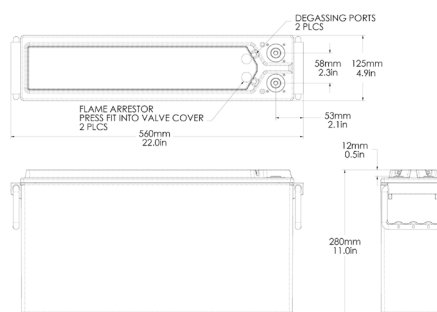

NSB 170FT and 190FT RED

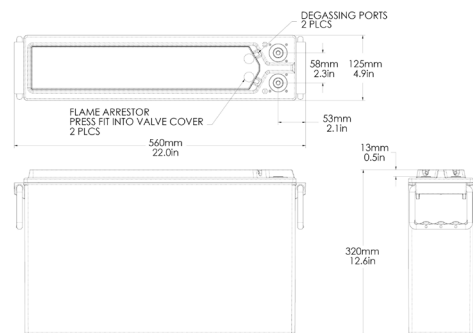

NorthStar Americas

NorthStar Battery Company LLC
4000 Continental Way
Springfield, MO, 65803,
United States of America
info@northstarbattery.com
Tel: +1 417 575 8200
Fax: +1 417 575 8250

NorthStar Europe

SiteTel Sweden AB
Haukadalsgatan 8A
164 40 Kista
Stockholm, Sweden
europe@northstarsitetel.com
Tel: +46 8 410 102 00
Fax: +46 8 638 06 00

NorthStar Middle East, Africa

NorthStar Battery DMCC
Office 702, Saba 1 Tower
Jumeirah Lake Towers, Dubai
United Arab Emirates
mea@northstarsitetel.com
Tel: +971 4 423 8060
Fax: +971 4 423 8061

NorthStar Asia-Pacific

NS Asia Pacific Sdn. Bhd.
B2-3A-13A, Solaris Dutamas
No. 1, Jalan Dutamas 1, 50480
Kuala Lumpur, Malaysia
asia@northstarbattery.com
Tel: +60 3 6419 0711

NorthStar China

Sitetel Sweden AB Shenzhen
International Chamber of Commerce Tower
Fuhua 3rd Road, Futian District
Shenzhen, 518017, China
china@northstarsitetel.com
Tel: +86 755 23832313

All NorthStar batteries are compliant with: Telcordia SR4228,
IEC 60896; Bellcore GR-63-Core, Issue 1; British, German, and
Russian telecom standards; UL approved and UN2800 certified.
NorthStar is registered to ISO 9001 and ISO 14001.